



Radio Receiver for BOSCH (Radion) Solution 3000 Intruder Alarms

1.0 Overview



The **TR800-433BR** is a 433MHz radio receiver compatible with the Bosch™ Solution 3000 series of intruder alarm panels. It emulates a Bosch **RADION B810** Receiver and also provides four outputs by emulating a Bosch **B308** Octo Output Module.

Solution™ and Radion™ are trademarks of Bosch Security Systems Pty Ltd.

Specification	Description
Dimensions (mm)	115w x 83d x 28h
Frequency	433.42MHz
Modulation	ASK
Compatible alarm panels	Solution™ 3000 (implementing SDI2 protocol).
Receiver emulation	Bosch B810 (Radion).
Output emulation	Bosch B308 (Octo Output Module).
Output modes	(a) Local Control: keyfob controls relays directly. (b) Panel Control: panel controls relay.
Compatible RF devices	(a) Bosch Keyfobs: RF3334E, RFPB-SB, RFPB-TB, RKF-FB (b) Connect Keyfobs: T433B . (c) Connect Night Arm Station: T433BNAS . (d) Bosch PIR: RFPR-12, RF940E . (e) Bosch Universal Transmitter: RFUN . (f) Bosch Smoke Detector: RF280ETHS .
Relay outputs	OUT1, OUT2: 1 Amp, NO/NC.
Open collector outputs	OUT3, OUT4: Open Collector.
Output timers	(a) Seconds: 1-255 (b) Minutes: 1-100
Max RF devices	48
Max keyfobs (for local relay control)	12 (retained during power down)
Weight	140g
Operating temp	0 deg C – 55 deg C
Operating voltage	12VDC (11.5V min, 13.8V max)
Operating current	30mA, no relays active. 25mA per relay on.

2.0 Types of Outputs

The outputs are either **Panel Controlled** or **Locally Controlled Outputs**:

Panel Outputs: controlled by keyfobs learned into the alarm panel.
Local Outputs: controlled by keyfobs learned directly into TR800.

3.0 Resetting the TR800-433BR

To delete all transmitters programmed into receiver, push **LEARN (SW3 on RF module)** and hold for 20 secs (NOTE: Doesn't reset Pulse Output Time):

- After 5 secs, LED does double flash (walk test mode).
- After 15 secs, LED does quick angry flash.
- After 20 secs, LED does 1s flash, all transmitters deleted.
- Release **LEARN**.

9.0 Panel Outputs: Setup

The **TR800-433BR** emulates a Bosch **RADION B810** receiver and also a Bosch **B308** Octo Output Module. The panel must be set to use these peripherals. Set the address of the receiver and octo module using DIPSW2:

SW2	Function	Off (0)	On (1)	Default	Note
S1	RECEIVER_ID	1	2	Off	1
S2	OCTO_ID	01 (11-14)	11 (111-114)	Off	2
S3	OCTO_ENAB	Disable	Enable	Off	
S4	DIAG	Off	On	Off	3

Note 1: Default RADION receiver ID. Default: OFF (1).

Note 2: S2 and S3 set Octo Output board emulation mode. To enable, set S3 ON then set base address with S2. To disable, set S3 OFF. **RESTART** after changing.

Note 3: Must be OFF.

4.0 Learning Keyfobs into Solution 3000 Alarm Panel

- Enter Master Code, followed by [1] and [#] (e.g 25801#).
- Choose user number then [#].
- Choose keyfob then press [#].
- Keyfob RFID displays. The letter "M" appears in the top right corner of the display (indicating Manual mode).
- Either:
 - Enter 9-digit RADION™ keyfob RFID, followed by [#]; or
 - Press [*] to switch to Auto mode (The letter "A" appears). Then press button 1 or 2 of keyfob until codepad shows the RFID number.
- Press [#] to confirm or [*] to cancel.
- Press Menu [-] to exit.

5.0 Deleting Keyfobs from Solution 3000 Alarm Panels

- Enter Master Code, followed by [1] and [#] (e.g 25801#).
- Choose user number 301-332 then [#].
- Choose keyfob then press [#].
- Press [*] to set Keyfob ID to 000000000.
- Press [#] to accept.
- Press Menu [-] to exit.

6.0 Learning PIR/Smoke/RFUN etc into Solution 3000

Please follow instructions for your alarm panel.

7.0 Local Controlled Outputs: Setup

***** READ CAREFULLY TO AVOID UNEXPECTED RESULTS *****

If BOTH Local and Panel Controlled Outputs are used, it is possible for them to conflict with each other. The user must ensure that an output is not controlled by both Local and Panel keyfobs.

SW1	Function	Off (0)	On (1)	Default	Note
S1	SDI2_RXD	Enabled	Disabled	Off	1
S2	SDI2_MODE	Enabled	Disabled	Off	1
S3	LOCAL_OUT1	Pulse Tmo	Toggle	Off	2
	LOCAL_OUT2	1s Pulse	Toggle		
S4	LOCAL_OUT3	1s Pulse	Toggle	Off	
	LOCAL_OUT4	1s Pulse	Toggle		

Note 1: For RADION operation, S1 and S2 must be both OFF.

Note 2: Pulse Tmo set as shown in Section 8

8.0 Local Controlled Outputs: Set Pulse Output Time (Default: 1s)

- Remove power.
- Press **LEARN** button.
- Apply power, still holding **LEARN**. LED will light then turn off when ready to count pulses.
- Press **LEARN 'x'** times to set the pulse output time to 'x'. LED flashes once per push.
- After entering the desired pulse output time, set the units:
 - Seconds:** Do nothing, the heartbeat will restart and the timer will be set in units of seconds. Range 1-255s.
 - Minutes:** Press and hold **LEARN**. When LED lights solid, release. Units will be set to minutes. Range 1-100m.

If no button press within 5 secs, times out and back to normal operation.

9.0 Local Outputs: Learning and Deleting Keyfobs

All Bosch compatible messages received by the TR800 are transmitted to the alarm panel. In addition, transmitters can be learned into the TR800 and buttons assigned to the outputs. To learn a transmitter (i.e., assign a button to an output):

- Press **LEARN** until LED goes off (approx 1s). Release. LED should be OFF.
- Select output to be programmed by pressing **LEARN** once for each output (1=OUT1, 2=OUT2, 3=OUT3, 4=OUT4). LED flashes each time button pushed and released. Then **EITHER**:

A	LEARN Keyfob button to output.	Press desired keyfob button. LED flashes once when learned.
B	LEARN Keyfob PANIC to output.	Press PANIC (B1+B2). LED flashes once when learned.
C	DELETE transmitter(s) learned to output. Use to delete lost transmitters, otherwise see Section 10.0.	Press LEARN and hold 2s (until LED does single long flash) to delete all transmitters which control the output. NOTE: if the same transmitter controls another output, it will be deleted from there also.

NOTE:

1. When learned, the output assigned to the transmitter will operate according to the DIP switch settings for that output.
2. The TR800-433B will exit learn mode after either 25 secs or when a transmitter has been successfully learned.
3. **If learning previously learned transmitter, there is no response.**
4. When receiver is full, any new transmitters overwrite the last.

10.0 Local Outputs: Deleting a Single Keyfob

1. Press **LEARN** until LED turns off (1s) then release.
2. Press PANIC buttons of keyfob to delete (B1+B2).
3. LED will do a **long flash**.

11.0 Local Outputs: Force On/Off Outputs

To assign a keyfob button to turn an output on **and a different** button on the same keyfob to turn the same output off:

1. Learn the button (B1-B4) required to turn output ON.
2. Learn the button (B1-B4) required to turn output OFF.

The first learned button turns output ON, the second turns it OFF.

IMPORTANT:

1. Force On/Off overrides DIP switch settings.
2. Having selected an output for Force On/Off, only use it for Force On/Off. **DO NOT** assign single buttons or sensors to it.
3. **DO NOT** use a button for Force On/Off control which is already assigned to another output.
4. If in doubt, reset the device (Section 3) before programming.

12.0 Walk Test Mode (Reduced Sensitivity)

Walk Test mode reduces the sensitivity of the receiver so that devices which work in this mode will work even better in normal mode (i.e., it provides a margin of safety). To enter Walk Test Mode, press **LEARN** button and hold for 5 secs until LED does double flash. Test all wireless devices.

To exit Walk Test Mode, press the **LEARN** button.

13.0 Link Settings

	Function	Description
J3	Reserved	n/a
J4	Set OUT+ Open Collector voltage for OUT3 & OUT4	Off: User wires to OUT+. On : OUT+ connected to 12V.
J5	COM1 voltage	Set COM1 pin to GND or 12V.

14.0 Tamper

The TR800 is fitted with a Tamper microswitch inside the lid. When activated (lid removed), a tamper condition is sent to the panel (SDI2_STATUS LED).

15.0 LED Flash Codes

LED1: RECEIVER (Red, Receiver Module)	LED Condition	Comments
1	Idle	Single short flash every 2 secs. Normal. No incoming data.
2	Msg from tx learned into rxr	Single long flash.
3	Msg from txr not learned	Double flash.
4	Walk Test	Double short flash every sec. Reduced sensitivity
5	Delete warning	Fast flash. About to delete all transmitters
6	Error	On with short double blink off. Data in txr system area corrupted.
7	EE Corrupt	Double long flash every 2 secs. One or more transmitter corrupt.
8	Power Fail	Off solid. Check power.

LED2: SDI2_COMMS (Red, Main PCB)	LED Condition	Comments
1	Idle	Single short flash every sec. Normal. Receiving data from panel (either B810 or B308 messages).
2	Receiver Module Fail	Two short flashes every sec. TR800 receiver module failure.
3	Panel Comms Fail	Three short flashes every sec. No B810 or B308 messages received.

LED3: SDI2_STATUS (Green, Main PCB)	LED Condition	Comments
1	Idle	Off Normal. No activity.
2	Rx data from unknown Txr	Single short flash Unknown keyfob.
3	Rx data from known Txr	Single long flash Known keyfob.
4	Tamper active	Double short flash Tamper switch on.
5	RF Jammed	Triple short flash Background noise.
6	Rxr being programmed	1 sec on, 1 sec off Data from panel.
7	Output	1 sec on, 1 sec off

16.0 Configuration and Connections

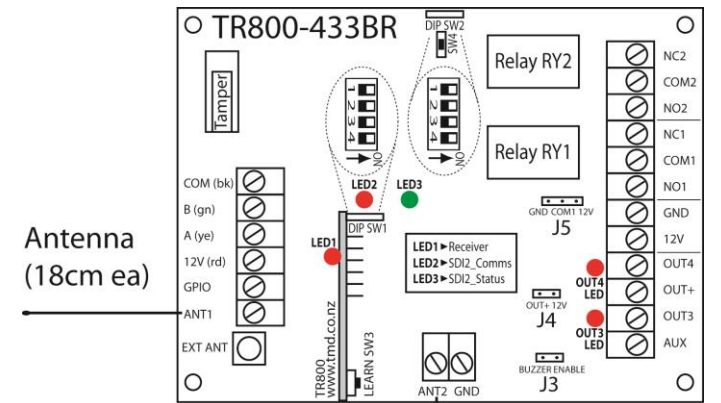

For best performance:

1. Ensure alarm panel is installed inside metal cabinet.
2. Allow 1m (min) between panel and TR800-433BR.
3. Keep antennas away from all metal and wires.

15.0 Connections

Pin	Label	Description
C1.1	AUX	Reserved
C1.2	OUT3	Open collector, 30mA. Wire relay coil to OUT+ Also drives onboard piezo (12V ext oscillator). OUT3_LED indicates status.
C1.3	OUT+	12V selectable by J4.
C1.4	OUT4	Open collector, 30mA. Wire relay coil to OUT+ OUT3_LED indicates status.
C1.5	12V	12V (11.5V-13.8V)
C1.6	GND	Ground
C1.7	NO1	RY1: Normally open contact
C1.8	COM1	RY1: Common
C1.9	NC1	RY1: Normally closed contact
C1.10	NO2	RY2: Normally open contact
C1.11	COM2	RY2: Common
C1.12	NC2	RY2: Normally closed contact
C2.1	COM	Panel: COM (black)
C2.2	B	Panel: B (green)
C2.3	A	Panel: A (yellow)
C2.4	12V	Panel: 12V (red)
C2.5	GPIO	General Purpose I/O (10k pullup, 2k isolation)
C2.6	ANT1	Antenna 1 Input
C3.1	ANT2	Antenna 2 Input
C3.2	GND	Ground

18.0 Connection to Bosch Alarm Panels

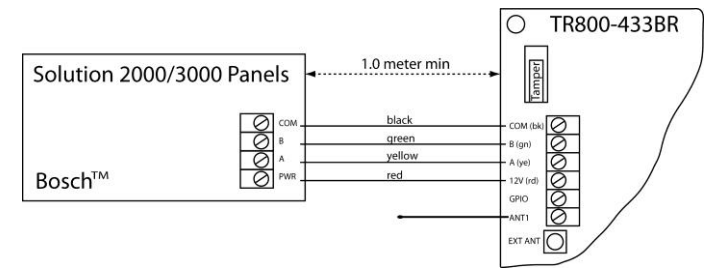

19.0 Mounting and Keyfob Button Assignments

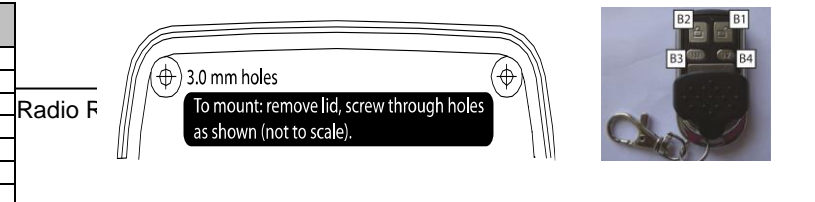

This product is designed and manufactured in New Zealand for Connect Security Products Limited.
Physical: 62 Aitken Terrace, Kingsland, Auckland.
Postal: P.O Box 8554, Symonds Street , Auckland.
Ph: +64 9 526 1060.
Web: www.csproducts.co.nz; Email: support@csproducts.co.nz

Warranty and Disclaimer: All information provided in this document is carefully prepared and offered in good faith as a guide for the installation, use and servicing of this product. We accept no responsibility for the incorrect operation, installation or use of this product and reserve the right to change specifications at any time and without notice. Liability of TMD Consultants, or any party involved in the design and/or manufacture of this product is limited to the repair or replacement of faulty product returned to us within 12 months from purchase and specifically excludes consequential loss or damage. **Full terms and conditions are available on request.**