

150506 - Pole Mounting Bracket

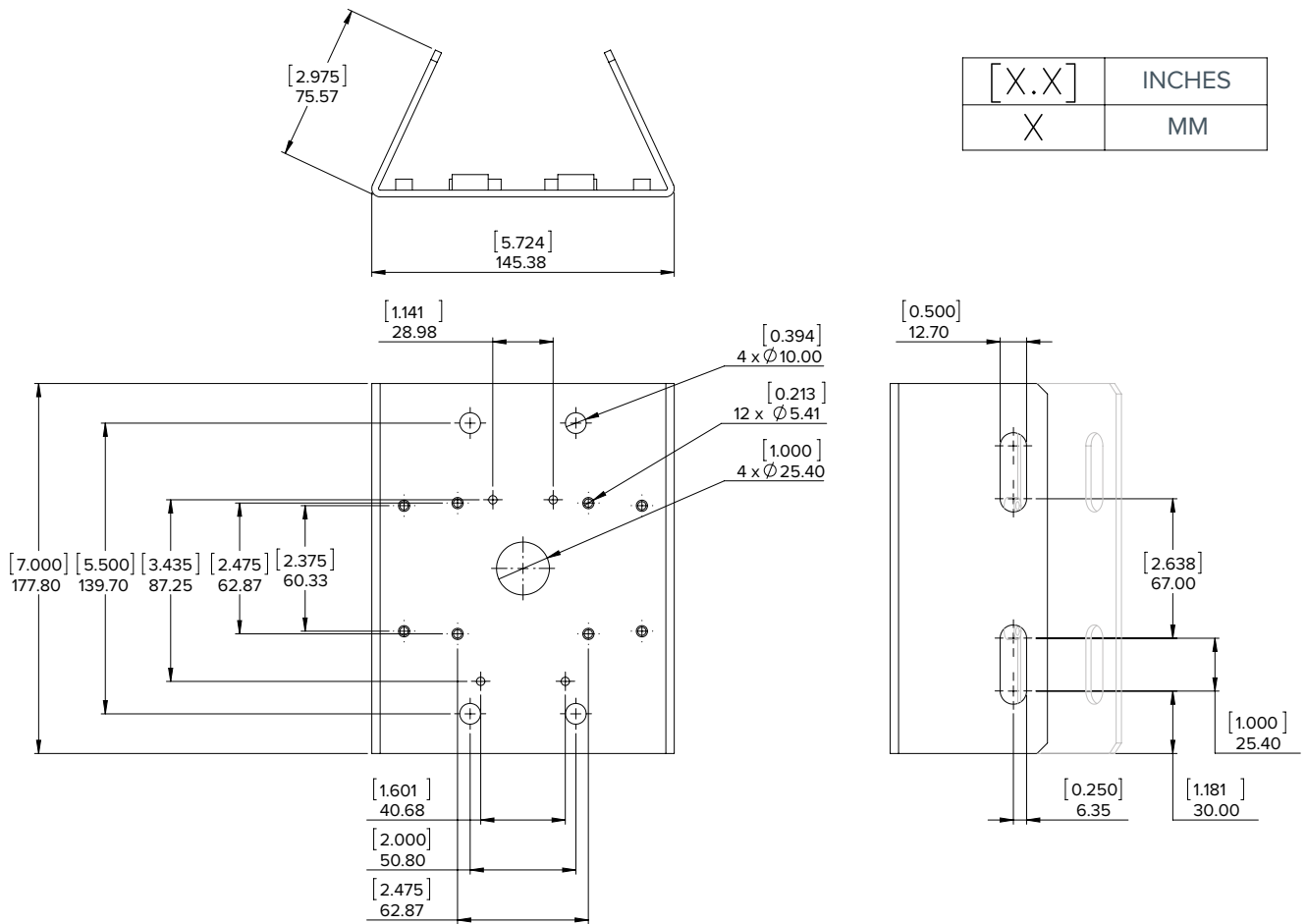

POLE-MNT 150506

Aluminum pole mounting bracket for dome cameras using the pendant wall mount and bullet cameras

Weight: 0.458 kg (1.01 lbs)

- Female inserts
- Compatible with:
 - Pendant Wall Mount (UX-DP-WALL_MNT) for UX-DP Pendant Dome Cameras
 - Pendant Wall Mount (BX-DP-WALL-MNT) for BX-D Dome Cameras
 - UX Bullet Cameras (UX-BO)
 - BX Bullet Camera (BX-BO)
 - HD Bullet Camera Junction Box (H4-BO-JBOX1)
 - Thermal Bullet Cameras (SP-BO)
 - Multisensor Camera (SP-MS)
- 6"–20" Metal straps included
- Minimum pole diameter is 152.4 mm (6")
- Maximum pole diameter is 508 mm (20")

RAL 9003 Included components for IndigoVision camera and accessories:

- 4 x Hex head bolts (3/8" – 16 x 1")
- 4 x Lock washers (3/8")
- 4 x Flat washers (3/8")
- 4 x Hex head bolts (M4-0.7 x 30)
- 4 x Lock washers (M4)
- 4 x Flat washers (M4)
- 2 x 6" – 20" Metal straps