

150505 - BX Pendant Wall Mount

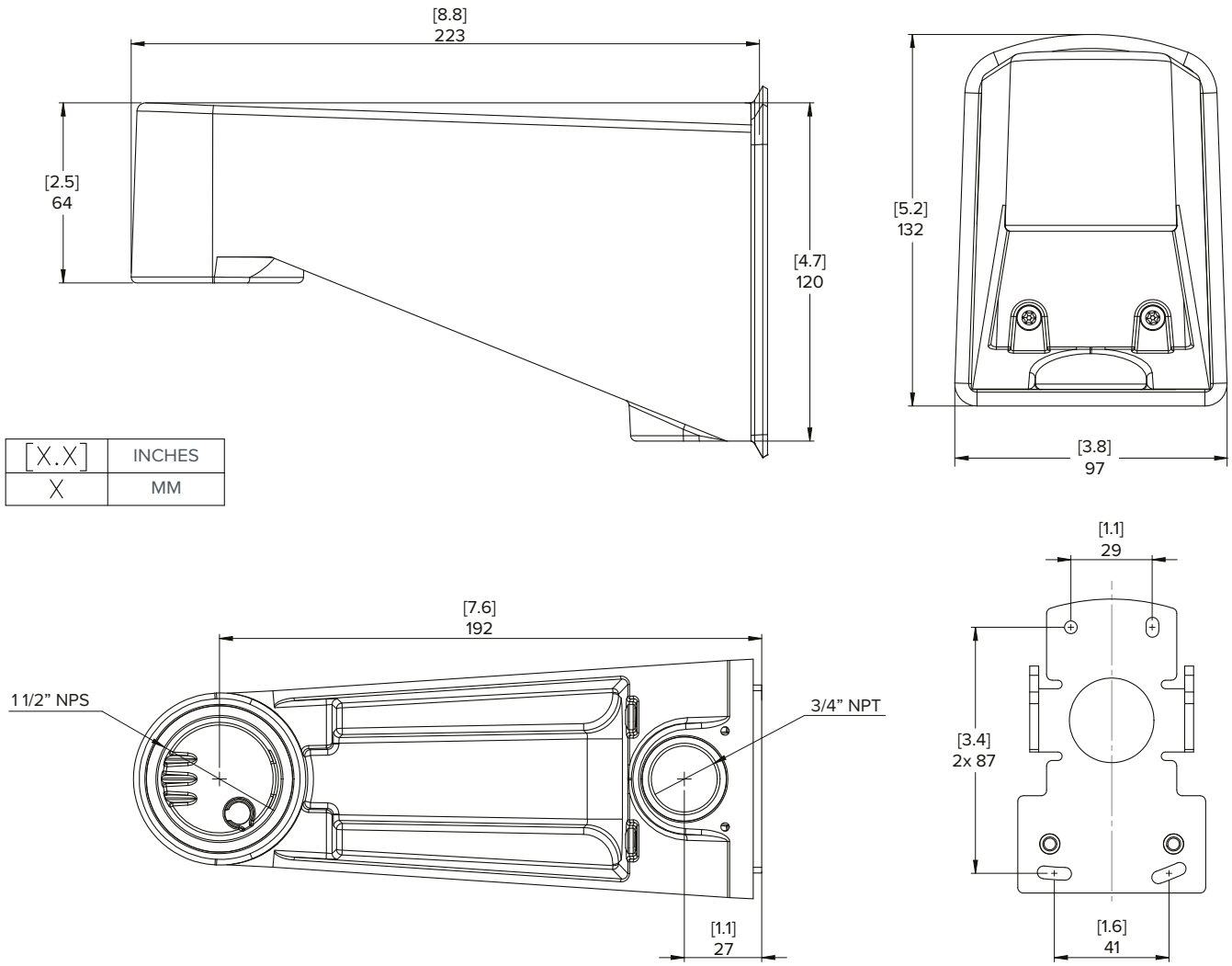

BX-DP-NPTA-MNT 150505

Pendant wall mount for dome cameras. Compatible with BX-DO dome cameras.

Weight: 1.27 kg (2.80 lbs)

Finish: Powder coat, RAL 9003 Body: Aluminum, stainless steel, silicone rubber

- Female 1-1/2" NPS camera mount
- 3/4" NPT conduit entry
- Creates outdoor seal with pendant dome cameras that meets IP66 standards